



KONGSBERG X SERIES

Tooling guide

Table of contents

Toolheads	4	Heavy-Duty Tools for PowerHead	31
FlexiHead	4	HD Knife 17	31
PowerHead	5	HD Knife 30	32
MultiCUT-HP	6	HD Bevel Knife	33
LubriCool		45° V-notch Knife	34
misting option for MultiCUT-HP	7	45° V-notch Knife, 10 mm	35
MultiCUT (1kW)	8	30° V-notch Knife	36
FoamHead	9	22.5° V-notch Knife	37
		15° V-notch Knife	38
Oscillating Knife Tools	10	15 mm Crease Wheel Adapter	39
Standard Reciprocating Knife Tool	10	26 mm Crease Wheel Adapter	40
Multi-Purpose, High-Frequency Knife Tool	11	60 mm Crease Wheel Adapter	41
Long Stroke Knife Tool	12	Crease Blade Adapter, 8 mm	42
Foam Knife Tool	13	Knife Blade Adapter	43
Rotary Cutting Tools	14	Specialty Tools	44
RotaCut Tool	14	Bevel Knife Tool for flexo plates and solid board	44
		Braille Tool	45
Static Knife Tools	15	Drill Tool	46
CorruSpeed Tool	15	Motorized Drill Tool	47
Rigid Material (RM) Knife Tool	16		
Psaligraphy Knife Tool	17	Accessories	48
General Purpose Static Knife Tool	18	X-pad	48
Single Edge Static Knife Tool	19	Tool Trolley	49
RBI90-16	20		
V-notch Knife Tools	21		
VI45-16	21		
VI45-10	22		
VI30-16	23		
Kiss Cutting Knife Tools	24		
MicroCut Knife Tool	24		
KissCut Knife Tool	25		
Crease Tools	26		
15 mm Crease Tool	26		
26 mm Crease Tool	27		
Crease Wheel Adapter	28		
Plotting Tools	29		
Ballpoint Pen Tool	29		
Fiber Tip Pen Tool	30		

FlexiHead

Sales code: 97AR5609



What is it used for?

The FlexiHead is typically used for folding carton, corrugated and most other paperboards. It combines highly accurate cutting with power and robustness, even for the most complex and compact materials such as solid board and the full range of synthetic materials used for packaging and displays.

It's also used for flexible materials. The FlexiHead is the only toolhead that features three tool positions for the full range of standard insert tools.

The maximum material thickness that can be cut is 20 mm (¾ in.). Using the Foam Knife you can cut up to 30 mm (1¼ in.), but this requires the high traverse clearance.

Materials

Folding carton, corrugated, plastic corrugated, solid board, fluted core board, flexible materials, corrugated plastic, flexographic clichés, thin foam.

Benefits

- Extremely versatile
- Very accuracy for fine details

Optional

- i-camera (97AR5527, included in the Sign Production kit)
- All standard Kongsberg X Series insert tools

PowerHead

Sales code: 97AR5610



What is it used for?

The PowerHead offers the possibility to crease, V-notch and cut straight lines at high speeds with a variety of adapters. This ensures superior performance on heavy-duty materials.

It features 150 mm (6 in.) diameter crease wheels with a scoring pressure equivalent to 50 kg (110 lbs), which is 2.5 times more than the down-pressure of the conventional tool stations. Sufficient to crease triple and double-wall corrugated with heavy liners. In addition it comes with two regular tool positions, which means that all standard insert tools can be used.

The large-size wheels also provide superior crease quality on recycled corrugated board, especially because a higher pressure can be applied without cracking the liner.

The HDU can offer V-notch cutting, with mitered corners and extremely precise folds for loading pallets, and container cushioning pieces, and paper core board displays.

Materials

All sorts of corrugated boards up to triple wall, including high recycled content, fluted core board, honeycomb, corrugated plastic, foam board.

Maximum material thickness 25 mm (1 in.). Using the Foam Knife you can cut up to 30 mm (1¼ in.) but this requires high traverse clearance.

Benefits

- 50 kg (110 lbs) down force
- Powerful head rotation
- Large variation of V-notch tools (angled cutting)
- HD knife tools

Included in package

- Crease wheel, Ø150 4-point
- Crease wheel, Ø150 6-point
- Crease wheel, U-shape Ø150

Optional

- i-camera (97AR5527, included in Sign Production kit)
- V-notch tools, HD tools, adapter for 15 mm crease, 26 mm crease, 60 mm crease and perforation wheels
- All standard Kongsberg X Series insert tools

MultiCUT-HP

Sales code: 97AR5611



What is it used for?

The MultiCUT-HP allows for milling, contour cutting, routing, drilling and engraving. It's suitable for high speed routing on a wide range of materials.

The 3kW milling spindle offers fast feed rates, thus considerably widening the bottleneck that routing jobs often present. The spindle features a 3kW of milling power and speeds up to 60,000 RPM. It is liquid cooled in order to utilize its full power potential. In addition

it comes with two regular tool positions, which means that all standard insert tools can be used.

The MultiCUT-HP includes a software function to supervise and monitor the spindle current, which is useful to adjust the feed rate and RPM settings for new materials.

Materials

Foamed PVC, solid PVC/PS, acrylic, aluminum composite material (ACM), MDF, wood, ...

The maximum material thickness that can be milled is 25 mm (1 inch) Knife cutting is about 20 mm. Using Foam Knife you can cut up to 30 mm [1 1/4 inch] but this requires high traverse clearance.

Benefits

- High quality routing at high speed
- High power, liquid cooled motor
- Large range of specialized and balanced milling bits
- Very fast milling bit exchange

Included in package

Milling starter kit for 6 mm shank:

- 1x Acrylic, single flute, 3 mm tip, 11 mm flute length
- 1x Acrylic, single flute, 5 mm tip, 22 mm flute length
- 1x Multi-purpose, 3 mm tip, 11 mm flute length
- 1x Multi-purpose, 5 mm tip, 22 mm flute length
- Felt Milling underlays: approx. 3 mm thick
- X-pad

Optional

- i-camera (97AR5527, included in the Sign Production kit)
- LubriCool Misting Option (97AR5661)
- Optional collet shank size: 3 mm
- Non-slip routing underlay

LubriCool misting option for MultiCUT-HP

Sales code: 97AR5661



What is it used for?

LubriCool is an option for the MultiCUT-HP. It cools the milling bit and lubricates the routing process. Resulting in significantly higher productivity and an extended lifespan of the milling bits on materials such as aluminum composite material (ACM) and some aluminum alloys.

The system is set up with a reservoir with special "oil" that is converted into a mist with the help of compressed air and a mixing zone. The mist is then sprayed directly onto the router bit via three nozzles during operation. Only a small drop of oil is needed every 10 seconds (factory preset). This small amount ensures that there is no trace left on samples and lowers consumption.

The system can be turned off when routing materials where misting is not beneficial.

Materials

Aluminum composite material (ACM), aluminum.

Benefits

- Higher productivity (runs faster with fewer passes)
- Smoother routing surface, less after work
- Extended lifespan of router bits

Included in package

- Routing liquid
- Extra suction ring
 - › This ring has a larger opening and should normally be used when routing materials where the LubriCool function is not in use, especially when routing materials that generate a large amount of dust or chips such as MDF, wood and acrylics

MultiCUT (1kW)

Sales code: 97AR5889



What is it used for?

The MultiCUT allows for entry level milling, contour cutting, routing, drilling and engraving. It's suitable for routing in a wide range of materials.

The spindle features a 1kW of milling power and speeds up to 45,000 RPM. The MultiCUT features an air-cooling feature for the milling bit important for the edge quality when milling acrylic and other synthetic materials.

In addition it comes with two regular tool positions, which means that all standard insert tools can be used.

Materials

Foamed PVC, solid PVC/PS, acrylic, aluminum composite material (ACM), MDF, wood, ...

The maximum material thickness that can be milled is 25 mm (1 in.).

Benefits

- High quality routing at high speed
- Large range of specialized and balanced milling bits
- Very fast milling bit exchange

Included in package

Milling starter kit for 6 mm shank:

- 1x Acrylic 3 mm, single flute, 3 mm tip, 11 mm flute length
- 1x Acrylic, single flute, 5 mm tip, 22 mm flute length
- 1x Multi-purpose, 3 mm tip, 11 mm flute length
- 1x Multi-purpose, 5 mm tip, 22 mm flute length
- Felt milling underlays: approx. 3 mm thick

Optional

- i-camera
- X-pad
- Optional collet shank size: 3 mm
- Non-slip routing underlay

FoamHead

Sales code: 97AR5612



What is it used for?

The Foam Head is a heavy duty tool made for cutting a large range of foam materials up to 86 mm (3 3/8 in.) thickness. These types of foam are typically used in the protective packaging industry.

The FoamHead is a reciprocating knife designed with characteristics optimal for low density porous material. It runs at a frequency of 4,800 strokes per minute and at amplitude of 4 mm. The great Z-axis control gives an advantage when cutting foam because it ensures consistent partial cut, which is very important with many foam designs.

Support wheels safeguard the user from the sharp blades and improve cutting abilities by applying pressure on top of the foam material.

Foam materials can normally be converted at a speed up to about 15 m/min with this tool depending on material quality. A wide range of blades also makes it suitable for honeycomb and fluted core board.

The FoamHead requires a high traverse clearance.

Materials

Polyethylene foam, expanded polystyrene, fluted core board, paper honeycomb board

Please note that some foam materials have a tendency to melt and stick to the knife. Materials with open cells might require additional support to hold down the material.

Benefits

- Perfect for cutting a wide range of foam materials at high speed
- Large range of specially designed blades for versatility
- Support wheels to hold the material down

Included in package

There are three adapters for round blades included, for up to 32 mm material thickness, for up to 55 mm material thickness and for up to 80 mm material thickness.

The adapters accept the BLD-SR63xx, BLD-SR65xx, BLD-SR68xx style blades. Two blades of each type are also included.

Optional

- Adapter for flat 40 mm blades (34014845)
- Adapter for flat 60 mm blades (34014803)
- Adapter for flat 86 mm blades (34002659)

Standard Reciprocating Knife Tool

Sales code: 97AR5598



What is it used for?

This tool is suitable for single and double wall corrugated board and other light-duty fibrous materials.

It runs at a frequency of 6,000 strokes per minute, with an amplitude of 0.3 mm. These properties, along with a powerful motor, enable cutting at full table speed on good quality materials.

A floating foot is used to reduce material tear and to keep the material down.

The cup is made of synthetic material to avoid scratching of printed surfaces.

Different knife adapters allow for different knife types. Maximum cutting thickness is 10-20 mm (3/8-3/4 in.) depending on blade.

Materials

Corrugated single wall, corrugated double wall, micro flute, soft foam board, corrugated plastic.

Benefits

- High speed (full machine speed on materials of good quality)
- Cuts a wide range of porous materials
- Wide range of durable, high quality knife blades

Included in package

Adapter for BLD-SR6xxx, including 3x BLD-SR6223 and 3x BLD-SR6224 knife blades

Optional

Works with a wide range of blades.

Multi-Purpose, High-Frequency Knife Tool

Sales code: 97AR5602



What is it used for?

The MP-HF Knife Tool is a high-frequency reciprocating knife tool for cutting a large variety of different materials.

It runs at a frequency of 12,000 strokes per minute, with an amplitude of 1.2 mm, which requires a reduced cutting speed compared to the Standard Reciprocating Knife Tools. These properties, along with a powerful motor, enable cutting of heavily recycled board at efficient speed.

A floating foot is used to reduce material tear and to keep the material down.

Materials

Corrugated material with high recycled content, fluted core board, honeycomb board, soft foam board, corrugated plastic, high density foam, ...

Maximum cutting thickness is 20 mm (3/4 in.)

Benefits

- Multi-purpose reciprocating knife tool for heavy-duty boards
- Good performance on boards with high recycled content
- Wide range of knife blades

Included in package

- Adapter for round BLD-SR6xxx blades, including 3x BLD-SR6223, 3x BLD-SR6224, 3x BLD-SR6310, and 3x BLD-SR6303 knife blades
- Gliding foot for 20 mm - 3/4" material cutting thickness

Optional

- Gasket package for MP-HF Knife tool (97AR505)
 - › The special BLD-SF3xx knife adapter and 4x BLD-SF312 and 4x BLD-SF313 knife blades for cutting in tough gasket materials
- Works with a wide range of blades.

Long Stroke Knife Tool

Sales code: 97AR5600



What is it used for?

This is a special variant of the reciprocating knife tool. The characteristic of this tool gives it excellent performance in materials like die ejection rubber, which makes it a perfect match for customers that like to take full advantage of the rubbering module in ArtiosCAD.

It runs at a frequency of 4,800 Strokes per minute, with an amplitude of 8 mm.

A floating foot is used to keep the material down.

Materials

Die ejection rubber with a maximum thickness of 20 mm (¾ in.), or roughly 10 mm (⅜ in.) with the foot mounted.

Benefits

Good performance on die ejection rubber.

Included in package

- Adapter for cylindrical blades (BLD-SR6xxx series)
- 3x BLD-SR6375 knife blades
- Gliding foot for 20 mm (¾ in.) cutting thickness

Foam Knife Tool

Sales code: 97AR5599



What is it used for?

The Foam Knife is a reciprocating knife tool for cutting a lot of different foam materials up to about 30 mm (1¼ in.). These types of foam are typically used in the protective packaging industry.

It runs at a frequency of 4,800 strokes per minute, with an amplitude of 4 mm, which requires a reduced cutting speed compared to other reciprocating knife tools. Foam materials can typically be converted at a speed of up to 15 m/min with this tool, depending on material quality.

The great Z-axis control gives an advantage when cutting foam because it ensures consistent partial cut, which is very important with many foam designs.

A floating foot is used to keep the material down.

Notes

This tool requires high traverse clearance.

Materials

Polyethylene foam, expanded polystyrene, fluted core board, paper honeycomb board.

Please note that some foam materials have a tendency to melt and stick to the knife. Materials with open cells might require additional support to hold down the material.

Benefits

- Perfect for cutting a wide range of foam materials at high speed
- Large range of specially designed blades for versatility

Included in package

- Adapter for BLD-SR63xx blades, incl. 5x BLD-SR6311
- Adapter for BLD-SF5xx blades, incl. 3x BLD-SF503
- Gliding foot

Optional

Works with a wide range of blades.

RotaCut Tool

Sales code: 97AR5603



What is it used for?

The RotaCut Tool is specifically developed for cutting textiles, canvas, mesh and other air transparent materials.

Since most textiles are more or less air transparent the vacuum hold-down system of the table will not be effective when cutting such materials. The RotaCut Tool has been designed with this in mind.

It operates by rotating a 10-facetted knife blade at 10,000 RPM. The blade protrudes from a slot in a foot that presses down on the material. The foot is made from a material that reduces friction to a minimum. These properties, in combination with the fibrous surface of the conveyor belt or felt underlays, provide a hold-down sufficient for cutting most textile materials.

Maximum cutting depth is 2 mm (.008 in.).

Materials

Textile, banner, canvas, mesh, carpet.

Benefits

- Floating foot for material hold
- High speed, 10-facetted knife blade
- Software controlled overcut function

Included in package

- 5x BLD-RC110 10-facetted knife blades
- Tools for blade change

Optional

Applicable knife blades BLD-RC10 10-facetted knife blade.

CorruSpeed Tool

Sales code: 97AR5689



What is it used for?

The CorruSpeed Tool is developed for cutting corrugated board at high speeds without oscillating. The CorruSpeed Tool achieves significant time savings on many corrugated boards, even with recycled content.

The CorruSpeed operates with a crushing cup, which in combination with controlled down pressure makes it possible to use a drag knife without tearing or cracking the liner.

Setting up the tool for different board qualities is easily done with help from adjustment dials.

The tool also comes with two edge-crushing cups with radii of 16 and 14.5, with 14.5 offering more pre-crushing. Which cup to use depends on the thickness and quality of the corrugated board.

The feet are easy to change; they are guided by pins and magnets and snap into place easily.

Materials

The CorruSpeed Tool is designed to work with corrugated board up to double wall BC flutes (7 mm).

Benefits

- High speed: in many cases the full machine speed
- Silent: the only noise you hear is the machine movement
- Smooth cut: the tool doesn't oscillate, so no tagged edges
- Pre-crushed lines: cutting lines are more similar to a die cut

Notes

For corrugated board with extremely short fibers and high recycled content, you might still need the properties of high frequency knife tools.

Included in package

- 2 crushing cups with radii of 16 and 14.5
- 8 standard knife blades: 2x BLD-SR8170, 2x BLD-SR8172, 2x BLD-DR8160, and 2x BLD-DR8180

Optional

Works with the BLD-SR/DR 8XXX blades.

Software requirements

iPC version 2.0 or higher.

Rigid Material (RM) Knife Tool

Sales code: 97AR5010



What is it used for?

The Rigid Material (RM) Knife Tool is a static knife tool suitable for a wide range of materials at high speed. There is a large selection of knife blades available, making it possible to cut everything from light weight detailed work to heavy rigid board such as 3 mm plastic foamed PVC.

The maximum cutting depth is defined by the blades, with a maximum cutting depth of 13 mm (½ in.).

Materials

Flexible plastic sheets, foamed PVC up to 3 mm, triple wall corrugated, soft foam board, corrugated plastic, cardboard, display board, vinyl, PVC banner.

Benefits

- A flexible all around knife tool, used for a wide range of applications
- Rigid board cutting at high speed
- High quality specially developed blades

Included in package

2x BLD-DR8160, 2x BLD-DR8180, 2x BLDSR8170, and 2x BLD-SR8172

Optional

- Works with all Kongsberg PCS knife blades in the BLD-SR/DR8xxx series, including asymmetric blades for burr-free edges
- Crease blades

Psaligraphy Knife Tool

Sales code: 97AR5521



What is it used for?

The Psaligraphy Knife Tool is specifically developed for fine details in thin materials like paper and folding carton. This is achieved by a spring loaded floating plastic foot in combination with special designed knife blades.

This tool is typically used for applications like greeting cards, invitation cards, promotional items, folding carton samples and psaligraphy art.

Materials

Fine detailed paper cut, folding carton.

Benefits

- Cuts out intricate details without lifting, moving or tearing the material
- High quality, specially designed knife blades with high durability
- User friendly plastic foot that snaps into place, guided by pins and magnets

Included in package

2x BLD-SR6150 and 2x BLD-SR6151 round shaft cutting blades.

Optional

Works well with all Kongsberg PCS knife blades in the BLD-SR/DR61xx series, including asymmetric blades for burr-free edges.

Software requirements

iPC version 1.2 or higher.

General Purpose Static Knife Tool

Sales code: 97AR623



What is it used for?

The General Purpose Static Knife Tool is suitable for a wide range of materials; it is typically used for flexible, paper based and rigid materials with thickness larger than 1 mm.

Materials

Flexible plastic sheets, cardboard, display board, vinyl, and PVC banner.

The maximum cutting depth is defined by the blades; with a standard maximum cutting depth of 3 mm (1/8 in.).

Benefits

A flexible all around knife tool, used for a wide range of applications.

Included in package

5x BLD-SF177, 5x BLD-SF224, and 3x BLD-SF238

Single Edge Static Knife Tool

Sales code: 97AR833



What is it used for?

The Single Edge Static Knife Tool is suitable for thin soft flexible materials like paper, folding carton, vinyl, ...

Materials

Flexible plastic sheets, folding carton, paper, vinyl.

The maximum cutting depth is 3 mm.

Benefits

- A flexible all around knife tool, for thin materials
- Thin, durable blades

Included in package

4x BLD-SF216 and 4x BLD-SF217

RBI90-16

Sales code: 97AR5407



What is it used for?

RBI90-16 (Rigid Board Insert 90-16) is made for high-speed straight cutting in rigid boards like fluted core board (Re-board, Falcon board, X-board), honeycomb board and triple wall corrugated.

One can get an extremely efficient production set up with the FlexiHead/PowerHead by using the RBI90-16 tool for high speed cutting of straight lines, the MP-HF Knife tool for cutting the curves, and V-notch tools for cutting folding lines.

Materials

Fluted core board, honeycomb board and triple wall corrugated.

Maximum cutting depth of up to 16 mm.

Benefits

- High-speed cutting of rigid boards
- Perfect combination for V-notch applications
- Specially designed, high quality blades

Included in package

2x BLD-SF290 specially designed knife blades

Optional

Works well with a wide range of Kongsberg PCS single flat knife blades.

Software requirements

XL Guide 6066, i-Cut 7.2.2, or iPC version 1.1 or higher.

VI45-16

Sales code: 97AR5313



What is it used for?

For 45° V-notch cutting in triple wall corrugated, corrugated plastic and fluted core board. It is typically used to make a 90° partially cut V-notch grooves for folding functionality, or a through-cut leaving a slanted cutting edge.

This tool is an insert tool which enables V-notch cutting with the MultiCUT, PowerHead and FlexiHead tool heads. When used in combination with a HD Knife tool or RBI90-16, you can have a highly efficient fluted core board converter.

Limited to straight lines only.

Materials

- Fluted core board, honeycomb board, soft foam board and triple wall corrugated
- Maximum cutting depth is 16 mm (5/8 in.)
- Please note that this tool is optimized for 16 mm thick board. If used on thinner materials, reduced cutting quality (wavy lines) may occur. If used on very thin or very rigid materials, the blade holder may loosen and fall off

Benefits

- Perfect 45° slanted folding lines in 16 mm thick material
- Specially designed, high quality knife blades

Included in package

- 1x BLD-DF571 and 1x BLD-DF572
- Safety foot for safe mounting

Optional

BLD-DF570 knife blades.

VI45-10

Sales code: 97AR5822



What is it used for?

For 45° V-notch cutting in corrugated, corrugated plastic and fluted core board. Its application is to make a 90° partially cut V-notch for folding functionality or a throughcut leaving a slanted cutting edge.

This tool is an insert tool which enables V-notch cutting with the MultiCUT, PowerHead and FlexiHead tool heads. When used in combination with a HD Knife tool or RBI90-16 one will have a highly efficient fluted core board converter.

Limited to straight lines only.

Materials

- Fluted core board, honeycomb board, soft foam board and triple wall corrugated
- Maximum cutting depth is 12 mm (½ in.)
- Please note that this tool is optimized for 10 to 12 mm thick boards

Benefits

- Perfect 45° slanted folding lines in 10 to 12 mm material
- Specially designed, high quality knife blades

Included in package

- 1x BLD-DF561 and 1x BLD-DF562
- Safety foot for safe mounting

Software requirements

iPC version 2.1 or higher.

VI30-16

Sales code: 97AR5823



What is it used for?

For 30° V-notch cutting in triple wall corrugated, corrugated plastic and fluted core board. Its application is to make a 60° partially cut V-notch for folding functionality or a through-cut leaving a slanted cutting edge.

This tool is an insert tool which enables V-notch cutting with the MultiCUT, PowerHead and FlexiHead tool heads. When used in combination with a HD Knife tool or RBI90-16 one will have a highly efficient fluted core board converter.

Limited to straight lines only.

Materials

- Fluted core board, honeycomb board, soft foam board and triple wall corrugated.
- Cutting depth is 16 mm (⅝ in.).
- Please note that this tool is optimized for 16 mm thick board. If used on thinner materials, reduced cutting quality (wavy lines) may occur. If used on very thin or very rigid materials, the blade holder may loosen and fall off

Benefits

- Perfect 30° slanted folding lines in 16 mm thick material
- Specially designed high quality knife blades

Included in package

- 1x BLD-DF571 and 1x BLD-DF572
- Safety foot for safe mounting

Optional

BLD-DF570 knife blades

Software requirements

iPC version 2.1 or higher.

MicroCut Knife Tool

Sales code: 97AR626



What is it used for?

The MicroCut Tool has been designed for applications where very fine depth tolerances are needed, such as varnish blankets and half-cuts in the thinnest folding cartons and adhesive vinyl.

The tool foot rides the surface of the material and features a digital micrometer for high precision control of the cutting depth, with display settings for mm or inches. Which ensures a perfect cutting depth measured from the material surface.

Materials

Varnish blankets, folding carton and vinyl.

Benefits

- Perfect and consistent cutting depth for partial cuts
- Micrometer precision
- Ensures perfect result for varnish blankets without touching the back liner

Included in package

5x BLD-SF110 and 5x BLD-SF177

Optional

(97AR948) Alternative material foot for varnish blankets to overcome high friction on some kinds of varnish blanket.

KissCut Knife Tool

Sales code: 97AR789



What is it used for?

The KissCut Knife Tool is a specialty tool for kiss cutting adhesive vinyl (decals) and foils. It's used for applications where it is important to keep the backing intact and only cut through the top film.

Due to the characteristics of the material, a spring loaded pressure is required in order to achieve perfect peel/weed quality. The pressure is manual set with a scale indicated turn key.

Material

Adhesive vinyl (decals), foil, diamond grade foil.

Benefits

- Perfect peeling/weeding quality
- Only the knife blade touches the material; preventing scratching of shiny and/or printed surfaces

Included in package

- 3x BLD-KC101 and 3x BLD-KC102 knife blades
- A foot for accurate depth control when more pressure is required
- Two different pressure springs

Optional

Kongsberg PCS knife blades in the BLD-KCxx series.

15 mm Crease Tool

Sales code: 97AR6029



What is it used for?

The 15 mm Crease Tool is suitable for thin material qualities. It enables applications that demand a very small and distinct crease line, mainly in materials such as folding carton and paper.

Materials

Paper and folding carton.

Benefits

- Fits in all toolhead insert positions
- Gives a distinct crease line in thin material

Included in package

2-point, 3-point, and double-edged 1 mm spacing crease wheels.

Optional

A wide range of 15 mm crease wheels with different pointage.

26 mm Crease Tool

Sales code: 97AR6028



What is it used for?

The 26 mm Crease Tool enables applications that demand a small sized creasing wheel on materials such as single wall corrugated, micro flute, corrugated plastic and folding carton.

Materials

Micro flute and single wall corrugated, corrugated plastic, folding carton.

Benefits

- Fits in all toolhead insert positions
- Gives a distinct crease line

Included in package

4-point, 6-point, and 10-point crease wheels.

Optional

A wide range of 26 mm crease wheels with different pointage.

Crease Wheel Adapter

Sales code: 97AR5408



What is it used for?

The 60 mm Crease Wheel offers the possibility to crease most corrugated thicknesses.

The medium-size wheels also allow for creasing with a higher pressure without cracking the liner, and with a limited over-crease.

It gives a sharper result to the 150 mm crease and at the same time allows harder pressure than the smaller wheel diameters.

The optional 60 mm Perforation Wheel pack offers the possibility to produce tear perforations at high speeds for corrugated board up to C flute (4 mm).

Materials

Single wall and double wall corrugated, micro flute.

Benefits

- Medium crease overcut
- Fits in all tool head insert positions

Included in package

- A 4-point wheel suitable for E-flute and Micro flute
- A 6-point wheel suitable for B- and C-flute
- U-shaped wheel for double wall corrugated

Optional

60 mm perforation wheel pack (97AR5517), for high speed perforation:

- Includes perforation wheel holder and four standard perforation patterns: 3x3 mm, 5x5 mm, 7x5 mm and 10x10 mm.
 - › *There is no software control on the wheel rotation, thus it is not possible to control how the perforation line starts (i.e. with a cut or with a space)*

Ballpoint Pen Tool

Sales code: 97AR688



What is it used for?

The Ballpoint Pen Tool is used for pen drawing, plotting and sample marking on materials such as folding carton, paper, cardboard and other paper based materials.

Included in package

2 pen refills; black, medium line weight.

Optional

Pen refills.

Fiber Tip Pen Tool

Sales code: 97AR639



What is it used for?

The Fiber Tip Tool option provides drawing capabilities on materials such as clear vinyl, which normally cannot be marked with ballpoint or liquid ink pens.

Included in package

8 multi-colored pen refills; medium line weight.

Optional

Pen refills; medium and thin line weight.

HD Knife 17

Sales code: 97AR379



What is it used for?

Heavy-duty knife tool for PowerHead is used for rigid board such as fluted core board, display board and triple wall material for fast straight cutting.

Maximum cutting thickness is 17 mm. Limited to straight lines longer than 50 mm (2 in.).

Materials

Fluted core board, triple wall corrugated, honeycomb board.

Benefits

- Frees up one tool position
- Straight rigid panel cutting at high speeds

Included in package

5x BLD-TZ129 knife blades

HD Knife 30

Sales code: 97AR725



What is it used for?

Heavy-duty knife tool used for fast straight cutting of rigid board such as fluted core board and honeycomb board material. The maximum cutting thickness is 30 mm. Limited to straight lines longer than 50 mm (1 1/4 in.).

Materials

Fluted core board, triple wall corrugated, honeycomb board.

Benefits

- Frees up one tool position
- Straight rigid panel cutting at high speeds

Included in package

2x BLD-TZ230, specially designed tungsten carbide knife blades.

HD Bevel Knife

Sales code: 97AR5821



What is it used for?

The HD Bevel Knife tool is suitable for a 45° slanted cut for v-notching or single through cutting.

The kit is developed for V-notching of folding lines in solid board (grey board) material using the special developed knife blade BLD-SF245.

The purpose is to create an exact, sharp 90° fold in materials that cannot be folded with conventional crease tooling.

Materials

Solid board and display board.

The maximum cutting depth is 6-7 mm.

Benefits

Perfect 45° slanted folding lines in thin materials.

Included in package

5x BLD-SF245 knife blades

Optional

BLD-SF212 knife blades

Software requirements

iPC version 2.1 or higher.

45° V-notch Knife

Sales code: 97AR620



What is it used for?

For 45° V-notch cutting on triple wall corrugated, corrugated plastic and fluted core board.

It's used to make a 90° partially cut V-notch grooves for folding functionality, or a through-cut leaving a slanted cutting edge.

Maximum cutting depth is 16 mm (5/8 in.). Limited to straight lines only.

Materials

Fluted core board, honeycomb board, soft foam board and triple wall corrugated.

Benefits

- Perfect 45° slanted folding lines for materials up to 16 mm in thickness
- Specially designed, high quality knife blades

Included in package

2x BLD-TZ511 and 5x BLD-TZ192 knife blades.

45° V-notch Knife, 10 mm

Sales code: 97AR274



What is it used for?

For 45° V-notch cutting of tougher materials like corrugated plastic.

Its application is to make 90° partial V-notch cuts for folding functionality, or a through-cut leaving a slanted cutting edge.

This will provide a more accurate cut in thinner material due to the shorter free end of the blade, which gives less flex.

Maximum cutting depth is 10 mm (3/8 in.). Limited to straight lines only.

Materials

Fluted core board, honeycomb board, soft foam board and triple wall corrugated.

Benefits

- Perfect 45° slanted folding lines in materials of up to 10 mm in thickness
- Specially designed, high quality knife blades

Included in package

2x BLD-TZ511 and 5x BLD-TZ192 knife blades.

30° V-notch Knife

Sales code: 97AR983



What is it used for?

For 30° V-notch cutting in triple wall corrugated, corrugated plastic and fluted core board. It's used to make 60° partial V-notch cuts for folding functionality, such as 6-sided polygonal pillars or a through-cut leaving a slanted cutting edge.

The maximum cutting depth is 16 mm (5/8 in.). Limited to straight lines only.

Materials

Fluted core board, honeycomb board, soft foam board and triple wall corrugated.

Benefits

- Perfect 30° slanted folding lines in materials of up to 16 mm thick
- Specially designed, high quality knife blades

Included in package

2x BLD-TZ511 and 5x BLD-TZ192 knife blades.

22.5° V-notch Knife

Sales code: 97A5763



What is it used for?

For 22.5° V-notch cutting in triple wall corrugated, corrugated plastic and fluted core board. It's used to make 45° partial V-notch cuts for folding functionality, for products such as octagonal pillars, or a through-cut leaving a slanted cutting edge.

The maximum cutting depth is 16 mm (5/8 in.). Limited to straight lines only.

Materials

Fluted core board, honeycomb board, soft foam board and triple wall corrugated.

Benefits

- Perfect 22.5° slanted folding lines in materials of up to 16 mm thick
- Specially designed, high quality knife blades

Included

2x BLD-TZ511 and 5x BLD-TZ192 knife blades.

Software requirements

iPC version 2.0 or higher.

Heavy-Duty Tools for PowerHead

15° V-notch Knife

Sales code: 97AR982



What is it used for?

For 15° V-notch cutting in triple wall corrugated, corrugated plastic and fluted core board. It's used to make 30° partial V-notch cuts for folding functionality, such as 12-sided polygonal pillars, or a through-cut leaving a slanted cutting edge.

Maximum cutting depth is 16 mm (5/8 in.). Limited to straight lines only.

Materials

Fluted core board, honeycomb board, soft foam board and triple wall corrugated.

Benefits

- Perfect 15° slanted folding lines in materials of up to 16 mm thick
- Specially designed, high quality knife blades

Included in package

2x BLD-TZ511 and 5x BLD-TZ192 knife blades.

Heavy-Duty Tools for PowerHead

15 mm Crease Wheel Adapter

Sales code: 97AR101

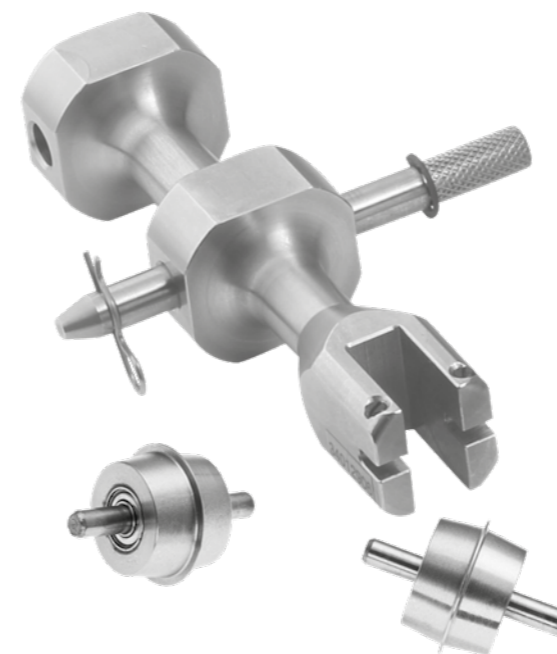

What is it used for?

An adapter for crease wheels with diameter 15 mm is available as an optional crease tool for the PowerHead HD position. This adapter is mainly used on thin materials such as folding carton and paper.

Materials

Paper and folding carton.

Benefits

- Frees up one tool position
- Use the 15 mm crease wheel in combination with high downforce
- Creasing in thin materials

Included in package

Adapter only.

Optional

All 15 mm crease wheels.

Heavy-Duty Tools for PowerHead

26 mm Crease Wheel Adapter

Sales code: 97AR100



What is it used for?

An adapter for crease wheels with diameter 26 mm is available as an optional crease tool for the PowerHead HD position. This adapter enables the use of a smaller sized wheel for micro flutes, folding carton and corrugated plastic. The smaller wheels and the heavy crease power aid in overcoming the 'memory' plastic materials tend to have.

Materials

Corrugated single wall, micro well, corrugated plastic, folding carton.

Benefits

- Frees up one tool position
- Use 26 mm crease wheel in combination with high downforce
- Creasing in tough plastic materials

Included in package

Adapter only.

Optional

All 26 mm crease wheels.

Heavy-Duty Tools for PowerHead

60 mm Crease Wheel Adapter

Sales code: 97AR5588



What is it used for?

The 60 mm Crease Wheel Adapter offers the possibility to crease most corrugated thicknesses.

The medium-size wheels also allow for creasing with a higher pressure without cracking the liner, and with limited over-crease.

It gives a sharper result to the 150 mm crease and at the same time allows more pressure than the smaller wheel diameters.

The optional 60 mm perforation wheel pack offers the possibility to produce tear perforations at high speeds for corrugated board up to C-flute (4 mm).

Materials

Single wall and double wall corrugated, micro flute corrugated.

Benefits

- Enables high speed perforation wheel cutting
- Enables high pressure, medium crease overcut

Included in package

Adapter only.

Optional

60 mm perforation wheel pack (97AR5517) for high speed perforation.

- Includes Perforation Wheel holder and four standard perforation patterns, 3x3 mm, 5x5 mm, 7x5 mm, and 10x10 mm.
 - › There is no software control on the wheel rotation, thus it is not possible to control how the perforation line starts (i.e. with a cut or with a space)
- A 4-point wheel suitable for E-flute and micro flute
- A 6-point wheel suitable for B-flute and C-flute
- U-shaped wheel for double wall corrugated

Heavy-Duty Tools for PowerHead

Crease Blade Adapter, 8 mm

Sales code: 97AR5955



What is it used for?

Crease blades are typically used for creasing flexible plastic sheets such as polypropylene.

With this type of material a blunt blade will achieve better folding results than what can be achieved with a crease wheel.

The adapter also accepts BLD-SR/DR8XXX blades.

Materials

Flexible plastic sheets, polypropylene.

Benefits

Creasing in tough flexible materials.

Included in package

- Crease Blade Adapter
- 0.5 mm crease blade
- 1.0 mm crease blade

Optional

All the 8 mm round shaft knife blades, BLD-SR/DRxxx.

Heavy-Duty Tools for PowerHead

Knife Blade Adapter

Sales code: 97AR5973



What is it used for?

The adapter accepts BLD-DF212 and BLD-DF213 knife blades, typically used together with the PressCut tool for trough cutting in combination with kiss cutting in adhesive vinyl and reflective foil.

Materials

Adhesive vinyl, reflective foil, diamond grade.

Benefits

Trough cutting in adhesive vinyl and reflective foil (diamond grade).

Included in package

- Knife Blade Adapter
- 1x BLD-DF212 knife blade
- 1x BLD-DF213 knife blade

Bevel Knife Tool for flexo plates and solid board

Sales code: 97AR475 & 97AR5314



What is it used for?

The Bevel Knife tool is suitable for a 45° slanted cut for v-notching or single through cutting. There are two Bevel Knife tool kits available, for two different applications.

The first kit enables high performance cutting of beveled edges in flexographic clichés using the special developed knife blade BLD-SF212.

The second kit is developed for V-notching of folding lines in solid board (grey board) material using the special developed knife blade BLD-SF245.

The purpose is to create an exact, sharp 90° fold in materials that cannot be folded with conventional crease tooling.

Materials

- Flexographic clichés, Solid board and display board.
- The maximum cutting depth is 6-7 mm.

Benefits

- Perfect 45° slanted folding lines in thin materials
- Perfect beveled edges in flexographic clichés

Included in package

- 97AR475 includes 2x BLD-SF212
- 97AR5314 includes 5x BLD-SF245

Braille Tool

Sales code: 97AR5396



What is it used for?

The Braille Tool enables the application of raised dots used in braille signage, the tactile writing system for people who are blind or visually impaired. Various government regulations make this tool necessary throughout the world.

The Braille tool inserts spheres into pre-drilled holes in rigid materials. The drilling requires the MultiCUT tool head and a special purpose milling bit. The Braille Tool is mounted as any other insert tool, into one of the free tool positions in the MultiCUT tool head.

The braille spheres are inserted into small holes by a spring in the tool. The tool is supplied with a plunger that has two purposes; to force the spheres into the internal funnel, and to indicate the number of spheres remaining in the tool.

Materials

Rigid materials like foamed PVC, PS, acrylic, ACM...

Benefits

Enables the creation of braille signage.

Included in package

The Braille Tool comes as a kit, including:

- 2 milling bits
- 10,000 clear acrylic spheres
- Various hand tools, samples and documentation on how to make braille signs

Optional

Range of different spheres.

Software requirements

XL Guide 6065, i-Cut 7.1 or iPC version 1.1 or higher.

Drill Tool

Sales code: 97AR449



What is it used for?

The drill tool is aimed at light-duty drilling in materials such as fluted core board, honeycomb board, soft foam board and triple wall corrugated.

Typically, a hole is drilled for the purpose of using special screws to attach shelves or other details in connection with displays, or as a way to close or join panels in heavy-duty shipping containers.

The drilling function is provided by the head rotation control, which spins the tool at about 1,000 RPM.

Materials

Fluted core board, honeycomb, soft foam board and triple wall corrugated.

Notes

The Drill Tool has been developed for relatively light-weight, paper-based materials and will not work with solid materials such as wood, plywood, MDF, foamed PVC (Forex/Sintra), acrylics, ...

Included in package

- 2 spanners for bit exchange
- 13 different bit collets for bit diameters, ranging from 1.0 to 7.0 mm, with 0.5 mm increments
- 2x 3 mm and 2x 4 mm drill bits

Motorized Drill Tool

Sales code: 97AR5068



What is it used for?

The tool insert consists of an electric drill, which fits in the FlexiHead, and a special 6.35 mm (¼ in.) diameter drill bit. Drill power is supplied through the connector for reciprocating tools on the tool head.

The drilling tool is equipped with an internal motor, which spins the tool up to 1,000 RPM.

Benefits

- Debris container inside the drill bit for longer operation
- Tungsten carbide drill bit with an extended lifespan
- The adjustable chuck accepts drill bits ranging from 0.5–6.5 mm (¼–¼ in.)

Materials

Flexo plates with a thickness of up to 7 mm.

Notes

No other reciprocating or rotary tool can be used when the drill is in use.

Included in package

Motorized Drill Tool with variable chuck, including a chuck key and one 6.35 mm (¼ in.) flexo drill bit.

Punching Tool

Sales code: 24121236732



What is it used for?

Designed to quickly and accurately create multiple small holes, with the hole size determined by the diameter of the installed punching bit. By collecting the removed core material in an internal reservoir, the tool ensures that no waste is left behind on the table, keeping the work surface clean and efficient. This makes it an ideal solution for producing precise perforations in a range of thin, not-too-dense materials such as plastic, paper, leather, and similar substrates, offering both speed and reliability in production workflows.

Benefits

- Fast and precise
- Cleaner punching process with no leftover waste on the table

Materials

Suitable for plastic, paper, leather, and other thin, lightweight materials that are not overly dense.

Notes

No other reciprocating or rotary tool can be used when the drill is in use.

Included in package

Punching Tool with 2 punching bits (3 mm and 5 mm in diameter)

Optional

Punching bits in a variety of diameters (0.8 mm, 1.0 mm, 1.5 mm, 2.0 mm, 2.5 mm, 3.0 mm, 3.5 mm, 4.0 mm, 5.0 mm, 5.5 mm, and 6.0 mm)

X-pad

Sales code: 97AR5293



What is it used for?

X-pad is a pressure-sensitive pad that very accurately calibrates the vertical operating level of all the tools.

X-pad is a device-connected to the control unit with a cable, placed on the tabletop only when needed.

The X-pad makes changing knife blades and milling bits much safer and faster because operator errors in connection with changes are eliminated. Such errors may destroy expensive material and, in serious cases, damage the cutting underlay or even the tabletop itself. X-pad is of particular importance for milling jobs that involve use of differently shaped milling bits.

Benefits

- Very fast tool changes
- Very fast tool calibration

Notes

To work properly, the X-pad itself must be calibrated. The following tools are applicable when the calibration procedure is carried out:

- Ballpoint Pen Tool, Braille Tool, CorruSpeed Knife Tool, Drill Tool, MultiCUT, MultiCUT-HP, Psaligraphy Knife Tool, RM Knife Tool

The X-pad is included in the MultiCUT-HP package.

Order your bits and blades online

Visit the Kongsberg Store to buy the best bits and blades for your Kongsberg cutting table.

store.kongsbergsystems.com

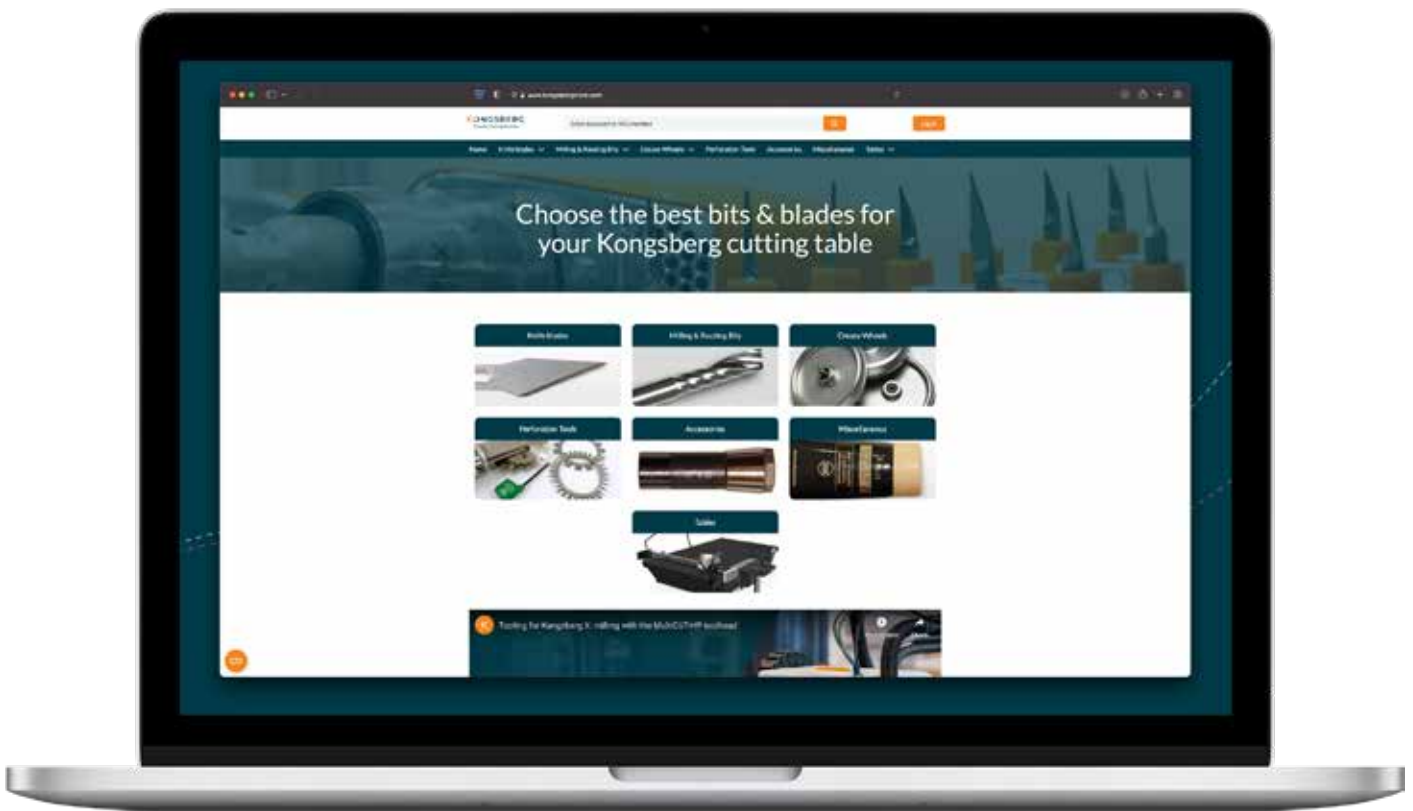

EMEA & APAC Kortrijksesteenweg 1087-B, 9051 Gent (BE)

| info.eur@kongsbergsystems.com
| info.apac@kongsbergsystems.com

Americas 1983 Byers Road, Miamisburg, OH 45342 (US)

| info.na@kongsbergsystems.com

www.kongsbergsystems.com

